

ML7420A/ML7425A,B

Electric Linear Valve Actuator

SPECIFICATION DATA



ML7420

ML7425

FEATURES

- Easy and quick installation
- No separate linkage required
- No adjustments required
- Low power consumption
- Force-limiting end stops
- Spring-return models (ML7425A,B)
- Manual operation knob
- Position feedback signal
- 0...10 Vdc or 2...10 Vdc signal input selectable
- Direct / reverse action selectable
- Stroke position on signal failure selectable
- Corrosion-resistant design
- Maintenance-free

SPECIFICATIONS

Temperature Limits

Ambient operating limits	-10...+50 °C at 5...95% r.h.
Ambient storage limits	-40...+70 °C at 5...95% r.h.
Medium valve temperature	Max. 150 °C (220 °C with High-Temperature kit)

Signals

Signal input voltage	y = 0...10 Vdc or 2...10 Vdc R _i = 100kΩ
Signal source	1 kΩ max.
Position feedback signal	x = 2...10 Vdc
Load	1 mA max.

Safety

Protection class	III as per EN60730-1
Protection standard	IP54 as per EN60529
Flame retardant housing	V0 as per UL94 (with metal cable gland)

GENERAL

The ML7420A / ML7425A,B actuators are designed for modulating control with controllers providing an analog output of 0...10 Vdc or 2...10 Vdc. They operate Honeywell's standard valves in heating, district heating, ventilation, and air conditioning (HVAC) applications. Spring-return models provide a safety position at power failure.

Wiring

Wiring terminals	1.5 mm ²
Cable entry	M20. Two additional knock-outs M18 and M20 for auxiliary switch and potentiometer accessories

Weight

non-spring return type	1.3 kg
spring return type	2.4 kg

Material

Cover	ABS-FR
Base	glass fiber reinforced plastic
Yoke	aluminum diecast

model number	ML7420A6009	ML7420A6017	ML7425A6008	ML7425B6007
supply voltage	24 Vac \pm 15%; 50/60 Hz			
power consumption	5 VA	7 VA	12 VA	
signal input 0(2) Vdc	Actuator stem retracted. Two-way valve:"open", three-way valve port A-AB:"closed" *			
signal input 10 Vdc	Actuator stem extended. Two-way valve:"closed", three-way valve port A-AB:"open" *			
stroke	20 mm			
run time at 50 Hz	1 min	0.5 min	1.8 min	
close-off force	\geq 600 N			
spring return time	—		\approx 12 s	
spring return direction	—		actuator stem extends at power failure	actuator stem retracts at power failure

* Factory setting; can be reversed by pressing the right-hand pushbutton (W3) located on the PCB (see Fig. 1).

OPERATION

General

The drive of a synchronous motor is converted into linear motion of the actuator stem via a spur gear transmission. The actuator stem is connected with the valve stem by a button-keyed retainer connection.

An integrated spring package limits the stem force to a factory-set value in either direction.

The actuator switches off precisely when the specified stem force is reached.

Manual Operation

Actuators without spring return are equipped with a manual operation knob used in case of power failure. Manual operation is permitted only after the power supply is switched off or disconnected.

To operate, push the manual operation knob down and turn clockwise to move the stem downward and counterclockwise to move the stem upward. If the actuator returns to automatic control, the manual operation knob unlocks automatically.

In the case of actuators with spring return, the manual operation knob is located under the cover.

Override Option

All actuators have an integrated override function (see also Fig. 3). When the override signal is applied, the actuator drives to the fully-open or fully-closed position, regardless of the controller signal.

Spring Return

The ML7425A,B spring return actuators provide a defined safety position of the valve in case of power failure.

The spring return actuators are shipped from the factory with a shipment stop (to lock the manual operation knob) in order to allow connection of the stem button retainer to the valve stem without power supply.

Electrical Installation

The actuators are delivered with a pre-installed cable gland M20 and two additional knock-outs for M18 and M20. Max. cable length/diameter for field mounting:

200 m / 1.5 mm² or

100 m / 1.5 mm² (ML7420A6017)

NOTE: To avoid malfunction, it is necessary to connect 24 Vac power and ground (see Fig. 3 on page 4).

Action

The direction of action can be reversed by pressing the left-hand pushbutton (W3) located on the printed circuit board (see Fig. 1). If the corresponding LED is lit, this indicates that the actuator stem will retract at a control signal of 0(2) Vdc (factory setting); if it is dark, the actuator stem will extend at a control signal of 0(2) Vdc.

Input Signal Range

The range of the analog input signal Y can be changed by pressing the right-hand pushbutton (W2) located on the printed circuit board (see Fig. 1). If the corresponding LED is lit, this indicates that the actuator is set for 0...10 V operation (factory setting); if it is dark, the actuator is set for 2...10 V operation.

Input Signal Failure

Using the potentiometer (W1) located on the printed circuit board (see Fig. 1), the actuator can be adjusted such that in case of a signal input failure (e.g. a broken wire), the actuator will run to any pre-configured position between 0% and 100%. The factory setting is with the actuator stem in the central position (50%).

NOTE: The two pushbuttons (W3 and W2) and the potentiometer (W1) are accessible after the cover has been removed and are located at the rear side of the protection sheet of the printed circuit board.

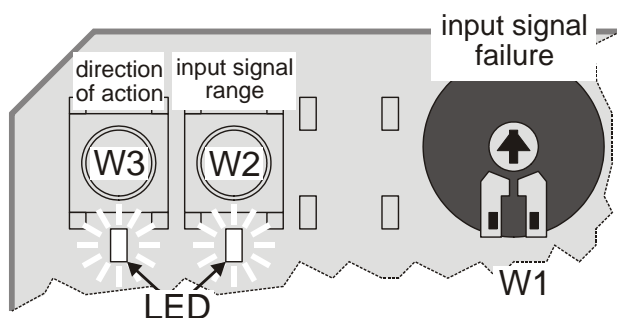

Fig. 1. Pushbuttons and potentiometer (default positions)

Output Signal "POSITION"

An analog output signal 2...10 Vdc "POSITION" is available which represents the actual actuator position. It can be used for remote indication.

When the actuator stem is extended, the output signal is 10 Vdc.

Accessories

Auxiliary Switches

The actuators can be equipped on-site with an auxiliary switch unit with two switches. Their switching points are adjustable over the full length of the actuator stroke. The switches can be used to switch pumps or provide remote indication of any stroke position. A cable gland M20 is delivered with the unit.

Part number: 43191680-205

High-Temperature Kit

(for applications >150°C medium temperature)

order number High-Temperature Kit	valve	DN
43196000-001	V5011A/V5011K	15 – 40
	V5013A/V5013G	15 – 40
	V5011R/V5013R	15 – 50
	V5328A/V5329A	15 – 32
43196000-002	V5011A	50
	V5013A/V5013G	50
	V5328A/V5329A	40 – 80
	V5049A	15 – 65
	V5050A	15 – 80
43196000-038	V5328A	100 – 150
	V5016A	100 – 150
	V5025A	100 – 150
	V5049A (PN25/40)	80 – 100
	V5050 (PN16)	100 – 150
	V5050 (PN25/40)	100

CLOSE-OFF PRESSURE RATINGS

stem force	600 N								
stroke	20 mm								
valve size	mm	15	20	25	32	40	50	65	80
	inch	½	¾	1	1 ¼	1 ½	2	2 ½	3
valves	close-off pressure ratings (in kPa)								
V5011R/S	1600	1600	1000	700	460	260			
V5328A	1600/1000	1000	1000	600	350	200	120	50	
V5016A	1600	1600	1600	1600	1600	1600	1600	1600	1600
V5025A	2500	2500	2500	2500	2500	2500	2500	2500	2500
V5049A	1600/1000	1000	1000	600	350	200	120		
V5013R/E	1600	1600	1000	700	460	260			
V5329C	600	600	600	600	480	260	160	100	
V5329A	1000	1000	1000	790	480	260	160	100	
V5050A	1000	1000	1000	600	350	200	120	50	

For details on the valves, see following Specification Data No.:

V5011R	EN0B-0064GE51	V5328A	EN0B-0432GE02	V5095A	EN0B-0412GE51
V5011S	EN0B-0085GE51	V5329A/5050A	EN0B-0310GE51	V5013R	EN0B-0065GE51
V5016A	EN0B-0440GE51	V5025A	EN0B-0442GE51	V5013E	EN0B-0446GE51
V5049A	EN0B-0238GE51				

DIMENSIONS

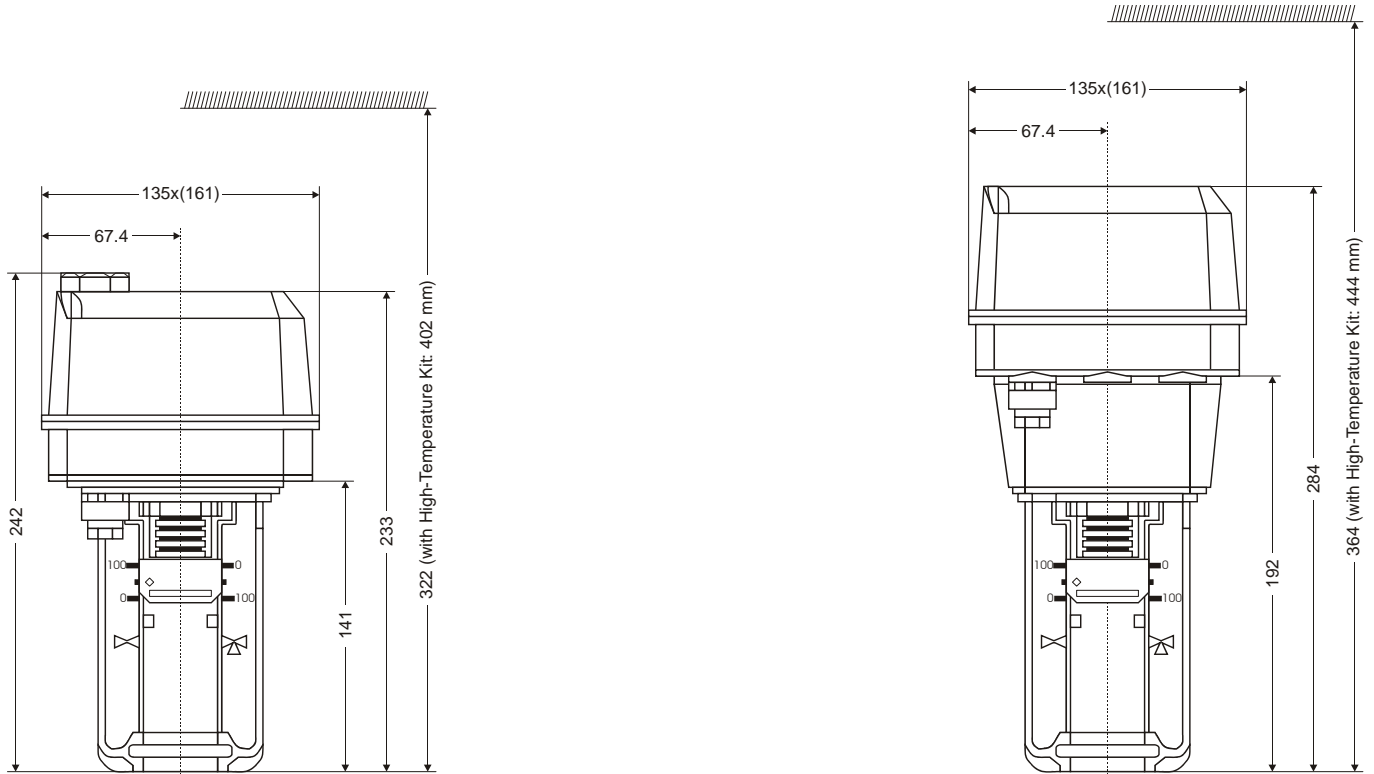

Fig. 2. ML7420A (left) and ML7425A,B (right), dimensions (in mm)

WIRING

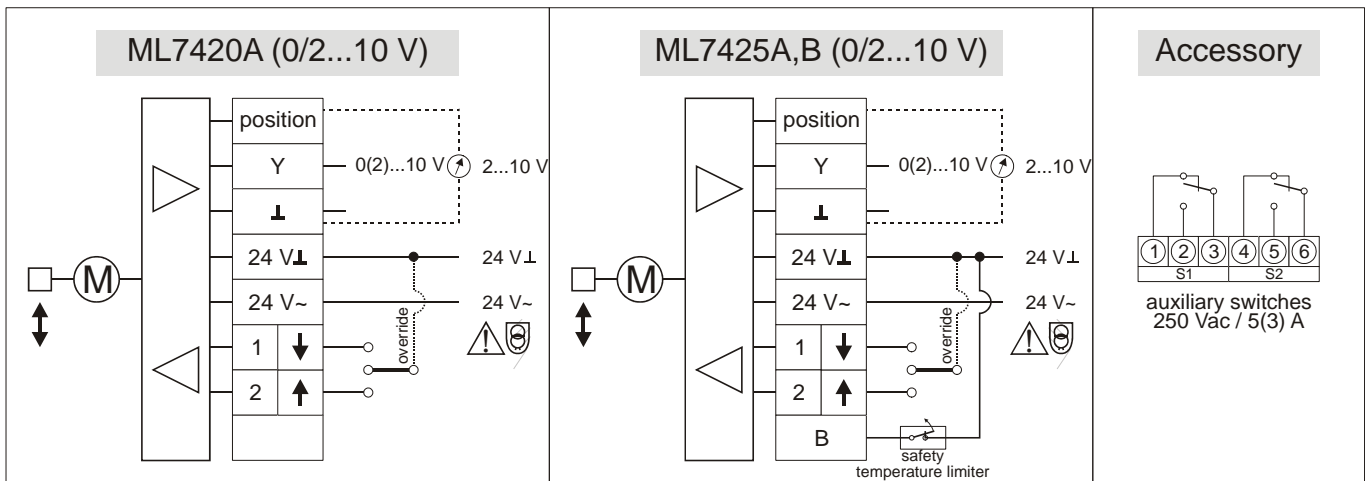

Fig. 3. Wiring

Honeywell

Manufactured for and on behalf of the Environmental and Combustion Controls Division of Honeywell Technologies Sarl, Ecublens, Route du Bois 37, Switzerland by its Authorized Representative:

Automation and Control Solutions

Honeywell GmbH
 Böblinger Straße 17
 D-71101 Schönaich
 Phone: (49) 7031 63701
 Fax: (49) 7031 637493
<http://europe.hbc.honeywell.com>

Subject to change without notice. Printed in Germany
 ENOB-0261GE51 R0606

**DIN EN ISO
 9001/14001**